

Drum Length(dm)  
 Drum Diameter(dm)  
 Countercurrent Tank  
 Drum Type  
 Magnetic Separator  
 Magnetic System with Rare Earth Magnetic steel  
 Double- Drum Type

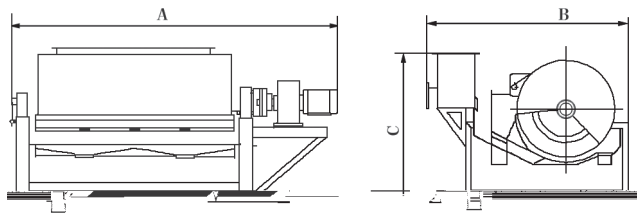
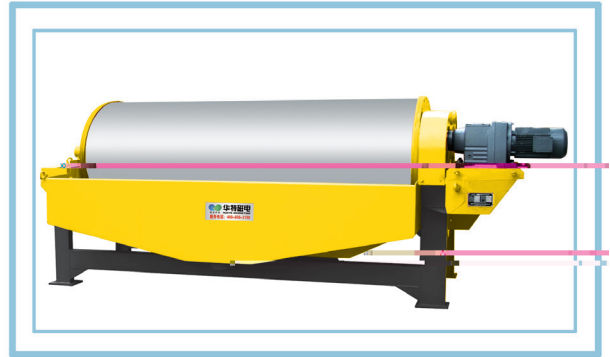

Appearance Size

General Technical Parameters:

Model	length (mm)	diameter(mm)		Processing Capacity (Mineral Concentration30%)	Appearance Size AxBxC mm	Motor Power kW	Weight (kg)	Drum Rotary speed r/ min
CTN1012	1050	1200	150 300	50-160	2650× 2170× 1705	3	2600	21
CTN1015		1500		70-200	2965× 2170× 1705	4	3200	
CTN1018		1800		90-260	3265× 2170× 1705	4	3700	
CTN1021		2100		120-300	3715× 2170× 1705	5.5	4200	
CTN1024		2400		150-400	4015× 2170× 1705	5.5	4900	
CTN1027		2700		180-350	4315× 2170× 1705	5.5	5500	
CTN1030		3000		230-400	4835× 2170× 1705	7.5	5900	
CTN1218	1200	1800	150 300	130-320	3265× 23805× 1935	5.5	4300	16
CTN1224		2400		190-380	4015× 23805× 1935	7.5	5600	
CTN1230		3000		280-460	4835× 23805× 1935	7.5	6400	



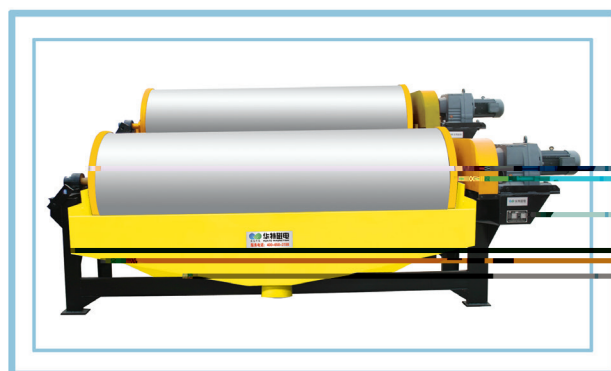
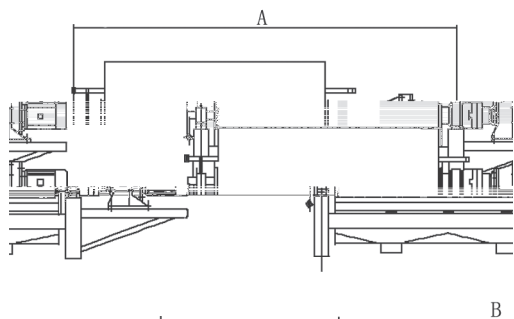

旋转方向  
Rotary Direction

刮板

Appearance Size

Work Principle

Model	Drum Length (mm)	Drum Diameter (mm)	Magnet intensity mT	30% m <sup>3</sup> /h Processing Capacity 30% of Mineral Pulp Concentration	Appearance Size Ax B x C mm	Motor power	Total Weight (kg)	Drum Rotary Speed r/min
2XCTN1012	1050	1200	150 300	50-160	2650×3130×1940	XWD3-6 1/71 Y100L-4 3KW	5600	21
2XCTN1015		1500		70-200	2965×3130×1940	XWD4-7 1/71 Y112M-4 4KW	6200	
2XCTN1018		1800		90-260	3265×3130×1940	XWD4-7 1/71 Y112M-4 4KW	7000	
2XCTN1021		2100		120-300	3715×3130×1940	XWD-5 5-7 1/71 Y132S-4 5.5KW	8100	
2XCTN1024		2400		150-400	4015×3130×1940	XWD5-5 7-1/71 Y132S-4 5.5KW	9500	
2XCTN1027		2700		180-350	4315×3130×1940	WD5-5 7-1/71 Y132S-4 5.5KW	10900	
2XCTN1030		3000		230-400	4835×3130×1940	XEDY7.5 8-1/71 Y132M-4 7.5KW	11140	
2XCTN1218	1200	1800	150 300	120-320	3265×3905×2735	XWDY7.5 8-1/59 Y160M-6 5.5KW	8300	16
2XCTN1224		2400		190-380	4015×3905×2735	XWDY5.5 7-1/59 Y132M-6 7.5KW	10800	
2XCTN1230		3000		280-460	4835×3905×2735	XWDY7.5 8-1/59 Y160M-6 7.5KW	3100	

